

KODAK XLT 7720

Digital

Continuous Tone

Printer



PRINTER PRODUCTS

Important safeguards and precautions

WARNING: *To reduce the risk of fire or electric shock hazard, do not expose the printer to rain or moisture.*

- **Read instructions**—All the safety and operating instructions should be read before operating the printer.
- **Retain instructions**—Keep all safety and operating instructions for future reference.
- **Retain packaging**—Use the original printer packaging for reshipment or long-term storage.
- **Heed warnings**—Adhere to all warnings on the printer and in the operating instructions.
- **Cleaning**—Unplug the printer from the wall outlet before cleaning the exterior of equipment. Do not use aerosol cleaners. Use a lint-free cloth for cleaning.
- **Power cord damage**—Avoid damage to the power cord. If damage should occur to the power cord, replace it with the specific cord for this unit.
- **Grounding**—The power cord is detachable and has a grounding prong for greater safety. To protect against power line surges, remove the power cord from the wall socket when not in use.
- **Power cord protection**—Route power cords so that they are not likely to be walked on or pinched by items placed upon or against them. Pay particular attention to cords at plugs, convenience receptacles, and the point where they exit from the printer.
- **Overloading**—Do not overload wall outlets and extension cords. This can result in a risk of fire or electric shock. See power specifications on rear-mounted data plate.
- **Servicing**—Do not attempt to service this printer yourself. Opening or removing covers may expose dangerous voltage or other hazards. Refer all servicing to qualified service personnel.
- **Liquid entry**—If dirt, liquid, or any other contaminant spills into the printer, contact your dealer or qualified service representative before operating the printer.
- **Ventilation**—The printer must have adequate ventilation. Provide clearances of approximately two inches from the external, rear surfaces of the printer, and at least 18 inches (46 cm) from the external front surfaces.

- **Power sources**—Operate the printer only from the type of power source indicated on the rear-mounted data plate.
- **Temperature**—Operation of this printer in ambient temperatures above 86° F (30° C) or below 59° F (15° C) may lead to degraded performance.
- **Humidity**—Operation of this printer in relative humidities above 76 percent may lead to degraded performance. This is of special concern in ambient temperatures between 75° F (24° C) and 86° F (30° C).
- **Orientation**—Do not operate the printer if its bottom is tilted more than 30 degrees from horizontal. For optimum operating conditions, the printer must be on a flat, firm, horizontal surface while used as a table-top model, or firmly attached inside an appropriate base while used in a rack-mount configuration.
- **Rack mounting**—The printer weighs approximately 130 lbs. (59 kg). This can present a hazardous situation when the printer is extended from its rack on rack slides. To prevent the rack from overturning, be sure to anchor it to a sturdy foundation or provide the rack with outrigger legs.
- **Hot surfaces**—Use caution when clearing paper jams or changing ribbon cartridges. Hot surfaces are marked with caution labels and may have temperatures exceeding 200° F (80° C).
- **Damage requiring service**—Unplug this printer from the wall outlet and refer servicing to qualified service personnel under the following conditions:
 - When the power cord or plug is damaged.
 - If liquid has been spilled or objects have fallen into the printer.
 - If the printer does not operate normally when following the operating instructions. Adjust only those controls that are covered by the operating instructions. An improper adjustment of other controls may result in damage and may require extensive work by a qualified technician to restore the printer to its normal operation.
 - If the printer has been dropped and/or the cabinet has been damaged.
 - When the unit exhibits a distinct change in performance—this indicates a need for service.

Table of contents

Read before using	iii
The <i>Kodak</i> XLT 7720 Digital Continuous Tone Printer	1
Capabilities	2
Features of the XLT 7720 printer	3
Color and tone scale adjustment	3
Image sensitometry tables	3
Color matrix	3
Speed shifts	4
Image sharpness enhancement	4
Image composition	5
Image manipulation	5
Scaling	5
Rotation	6
Annotation	6
Mirror image	6
Time and date	7
Audio alert	7
A choice of hard copy	8
Paper prints	9
Transparencies	9
Ribbons	10
Installing the XLT 7720 printer	11
Installing the side panel or rack and slide mount kits	11
Unlocking the drum assembly	11
Line voltage conversion	12
100 V AC line conversion	13
220 V AC line conversion	14
240 V AC line conversion	16
Computer interface options	18
Connecting to the host computer	18
Installing printer driver software	18
Using the XLT 7720 printer	19
Controls and indicators	19
Powering up	22
Making a sample print	23
Installing the <i>Kodak Ektatherm</i> ribbon cartridge	23
Loading <i>Kodak Ektatherm</i> print paper or transparency material	26

Using the XLT 7720 printer (cont.)	
Handling your <i>Kodak Ektatherm</i> products	30
General	30
Ribbon cartridges	30
Paper prints and transparencies	30
Paper and transparency material	31
Clearing jams in the printer	32
Clearing a jam in the print tray	32
Clearing material on the print drum under error conditions	33
Clearing a jam in the finishing station	33
Maintaining the printer	34
Good housekeeping	34
Cleaning the print head	34
Replacing a fuse	35
Replacing the air filter	36
Replacing the battery	37
Troubleshooting	38
Technical support and service	46
In case of difficulty	46
Technical support	46
Glossary	47
Specifications and general data	49
Printing specifications	49
Physical/environmental specifications	50
Options and accessories	51
<i>Kodak XLT 7720 Digital Continuous Tone Printer</i> (configuration options)	51
<i>Kodak Ektatherm</i> products hard copy output options	51
<i>Kodak Ektatherm</i> ribbon cartridge options	51
Accessories	52
Index	Index-1
Warranty	

Read before using

For best performance, the *Kodak XLT 7720 Digital Continuous Tone Printer* should be operated according to the guidelines in this manual. Please read the rest of the manual thoroughly before attempting to set up and operate the printer.

This *User's Manual* provides information you will need to understand the printer's operation, become aware of its many features, and maintain the printer in peak operating condition. Most of your questions about the printer are answered in this manual. However, the XLT 7720 printer is a computer peripheral, and has limited stand-alone functionality. Only the host computer's specific printer driver manual can fully describe the printer's operating procedure when it functions as part of a system.

NOTE: The XLT 7720 printer is shipped from the factory configured to operate at 120 V AC, 50/60 Hz. To prevent accidental operation at other power line voltages, a red **120 V** sticker covers the power cord receptacle located at the rear of the printer. This sticker must be removed to gain access to the receptacle.

If other operating voltages are required, refer to "Line voltage conversion" for additional information.

The Kodak XLT 7720 Digital Continuous Tone Printer

The Kodak XLT 7720 Digital Continuous Tone Printer converts digital image data from a host computer into color or black-and-white prints of a quality approaching that of traditional photographs. The printer does this electronically, without light-forming optics, wet processing chemicals, or a separate fusing process. The printer is self-contained; its only external connectors are the power cord and computer interface cable (IEEE 488 or SCSI). It may be configured for either rack mounting or table-top operation.

The XLT 7720 printer produces images on paper and transparency bases which have the quality, texture, and feel of standard photographic materials. Both paper and transparency materials are available in 8.5 x 11-inch (216 x 279 mm), 11 x 11-inch (279 x 279 mm), and A4 (210 x 297 mm, 8.3 x 11.7 in.) sizes and are supplied in packs of 100 sheets for easy loading into the printer.

The host computer loads all image data into the printer's memory buffer before printing begins—up to 12 MBytes for an 11 x 11-inch, 24-bit color image or up to 4 MBytes for an 11 x 11-inch, 8-bit, black-and-white image. The XLT 7720 printer operates through a process called "thermal dye transfer." During printing, a drum moves the paper or transparency material and a dye-carrying ribbon past a thermal print head. The head contains 2048 individual heating elements. Precise thermal control of each element drives the appropriate amount of transparent dye from the ribbon onto the paper or transparency material, thus forming a continuous-tone picture.

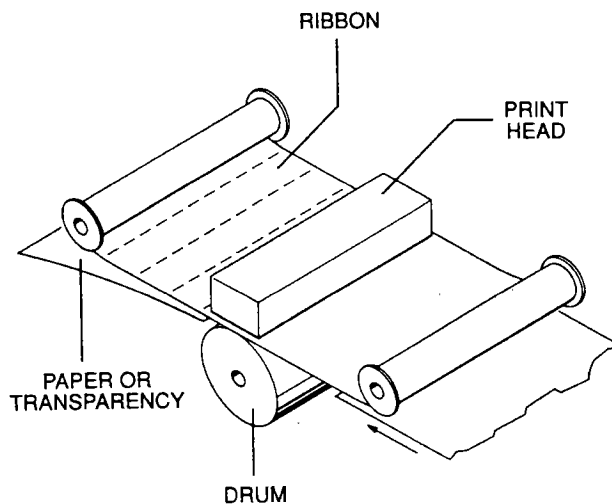

Capabilities

A number of features, which enable manipulation of the image itself, add usefulness and flexibility to the XLT 7720 printer.

NOTE: These capabilities of the printer are controlled through the software printer driver installed in your host computer. Your specific software driver may not implement every one of the XLT 7720 printer's built-in features.

With the XLT 7720 printer you can:

- Change the size of the image.
- Load any number of image segments into the printer memory to compose a full page image.
- Adjust the tone scale and color balance of the image.
- Annotate the image with ASCII text strings in any of six font options.
- Modify the sharpness of text and object edges in the image.
- Rotate the image 90 degrees.
- Produce a mirror image.
- Make any number of copies from the image that is stored in memory.

Refer to "Features of the XLT 7720 printer" for detailed descriptions of each of these capabilities.

Features of the XLT 7720 printer

NOTE: All of the following features are controlled through the software printer driver installed in your host computer. Your specific software driver may not implement every one of the printer's built-in features.

Color and tone scale adjustment

The controller and firmware inside the XLT 7720 printer enable you to adjust the color and tonal rendition of prints and transparencies. Adjustment is usually required to match the print to your computer monitor or to a hard copy reference, such as a printed page or photograph. These adjustments are made possible through image sensitometry table and a color matrix.

An image sensitometry table adjusts the overall print tone scale and color balance. The color matrix adjusts the hue and saturation. You can select one of several pre-defined tables or matrices, or you can create them using an application such as *Kodak TableMaker™* software.

The following paragraphs provide a generic discussion of the image sensitometry tables and the color matrix.

Image sensitometry tables

The image sensitometry tables convert the 256 levels (each) of red, green, and blue per pixel in the displayed image to the specific density levels in the final print. The tables control the tone reproduction in the print, and are crucial for obtaining the optimum match between the print and the image displayed on the monitor.

The tables allow you to independently match the luminance level of the red, blue, and green colors in the print to the corresponding colors seen on the monitor or in the reference print. You can also independently adjust the appearance of the shadow, mid-scale, and highlight portions of the tone scale, as well as the overall color balance.

Color matrix

Tone reproduction plays a significant role in the color matching process. If the tone reproduction is correct and if the colors in an image are within the color gamuts of both the printer and the monitor, the color match between the print and the monitor should be acceptable.

However, the following variables can affect the color match between the print and the monitor:

- The color temperature, or white point of the monitor
- The color temperature of the ambient lighting
- The optical properties of the dyes used in the printing process.

The XLT 7720 printer has a built-in color matrix that adjusts the density level in one color (in a given pixel) as a function of the signal sent to the other two colors. This matrix operation allows you to adjust the saturation level of all colors. It also allows a hue shift of up to ± 50 degrees on a 360-degree color wheel.

Speed shifts

Speed shifts allow you to make uniform color and density corrections to a single image *without* modifying the image sensitometry table. This is done by applying a digital offset (plus or minus) to produce a lighter or darker image. Speed shifts may clip data at one end of the tone scale.

Image sharpness enhancement

The XLT 7720 printer can process images to alter or enhance the apparent sharpness of a print or transparency. The following levels of enhancement are available:

Prints: none, low, normal, high, and extra high.

Transparencies: none, low, normal, and high.

The *normal levels of enhancement* produce a print or transparency with the most uniform frequency response possible with the printer. *Low enhancement* and *no enhancement* settings produce prints or transparencies with some contrast suppression in the fine detail of the picture. These will appear to be slightly unfocused. *High levels of enhancement* provide a contrast boost in the fine detail of the print or transparency and, hence, will appear sharper than the default level.

Enhancement settings should depend upon scene content and the intended use of the print. Most of the time the normal setting will produce the best result. An image containing artifacts from a noise source (e.g., scan lines or high frequency sensor noise) may be best printed with either no enhancement or a low level of enhancement. A highly structured scene which will be projected as an overhead transparency may be best printed with a high level of enhancement.

Image composition

A print or transparency may comprise a number of distinct, rectangular images that can be placed anywhere on the page as segments of a mosaic-like picture. Each segment can be loaded into printer memory and can be any size compatible with space available in the memory. Each image segment must be loaded using the same scale factor.

Image manipulation

You can modify your images by using the scaling, rotation, annotation, mirror image, or time and date stamp feature. Each of these features is described in the following paragraphs.

Scaling

The resolution of the XLT 7720 printer is 203 pixels per inch (8 pixels per mm). By scaling the size of the image file you can change the dimensions of the picture. The printer can reduce the picture up to one fourth of its original size, enlarge it up to four times its original size, or scale the picture in one-per cent increments to any size between those limits. The vertical and horizontal dimensions of the picture can be scaled independently.

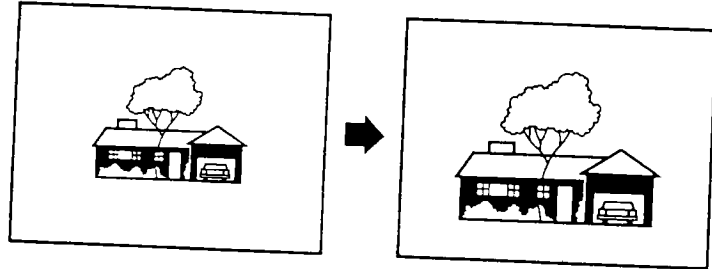

Scaling occurs when the image is loaded into the buffer. The scaled image cannot exceed the buffer or paper capacity.

Rotation

If you are printing onto 8.5 x 11-inch or A4 print material, you can designate whether an image prints in a normal orientation or is rotated clockwise by 90 degrees. This allows a picture to change from landscape to portrait format, and vice versa.

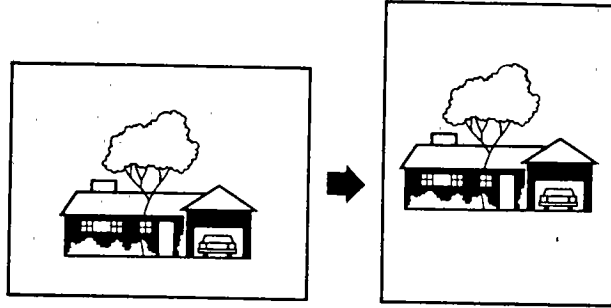

The horizontal and vertical limits of the image space are the only parameters affected by the rotation. The downloaded image is otherwise unchanged.

Annotation

There are two ways to overlay alphanumeric text at any desired location on an image. The image itself may contain text that is printed as part of the picture, or you can add ASCII text strings to the picture. The font used for printer-generated text provides optimum quality with the thermal dye transfer process and is available in 12-, 18-, and 28-point bold and 8-, 12-, 18-point normal.

Mirror image

A mirror image transparency is often useful for activities such as annotating the image by writing on the backside of the transparency while projecting it image-side down. In addition, mirror image negatives can be used for contact printmasters. The same image file created to produce a right-reading picture can be used for the mirror image.

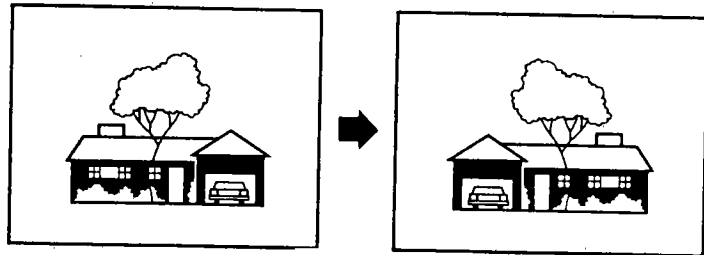

Time and date

An internal clock maintains the current time and date, and a backup battery keeps the clock up-to-date when printer power is off. The current time and date may be annotated in the printer's smallest font (8 point) onto an image by enabling the time and date stamp feature.

The format of the time and date stamp is: the numeric day of the month, a three-character month abbreviation (displayed in the language set at the rear of the printer), and a four-digit year (e.g., 15-Aug-1991). Black characters are imposed on a white background. Characters are printed in a proportionally spaced font.

The time and date stamp is printed in the lower right-hand corner of the picture and will overwrite any image in that location. Image scaling does not affect the stamp, but picture sharpness enhancement, mirror image, image rotation, and multilingual support do affect it.

Audio alert

If enabled, an audio alert sounds when a print has been completed or when the printer requires the operator's attention (i.e., when the display shows an error code).

A choice of hard copy

The *Kodak* XLT 7720 printer offers a choice of paper print or transparency density range, access time, and material usage appropriate for your application.

Mode	Maximum Density	Printing Passes Required	Printing Time Required (minutes)*		
			8.5 x 11	11 x 11	A4
B&W Paper (XL 300-B ribbon)	2.5	1	1.6	1.9	1.9
Color Paper (XL 100-C ribbon)	2.5	1	3.2	3.9	3.9
Color Paper (XLT 100-C ribbon)	2.5	1	3.2	3.9	3.9
B&W Transparencies (XL 300-B ribbon)					
—Low Density	1.7	1	2.2	2.8	2.8
—Normal Density	2.1	2	2.4	2.9	2.9
—High Density	2.7	2	3.2	4.1	4.1
Color Transparencies (XL 100-C ribbon)					
—Low Density	1.5	1	5.1	6.5	6.5
—Normal Density	2.2	2	6.8	8.5	8.5
—High Density	2.7	2	9.4	11.7	11.7
Color Transparencies (XLT 100-C ribbon)					
—Low Density	1.5	1	3.2	3.9	3.9
—Intermediate Density	1.9	1	3.8	4.8	4.8
—Normal Density	2.2	2	5.5	6.9	6.9
—High Density	2.7	2	5.6	6.9	6.9

* Time does not include downloading the image data from the host computer.

Nine different types of hard copy are available from the XLT 7720 printer. Paper prints are available in either black-and-white or color. The printer also produces color transparencies at four different density levels, and black-and-white transparencies at three different density levels. Each of these types is available in 8.5 x 11-inch, 11 x 11-inch, and A4 (210 x 297 mm) formats, with maximum image sizes of 7.6 x 10.1 inches (192 x 256 mm) for 8.5 x 11-inch and A4-size material, and 10.1 x 10.1 inches (256 x 256 mm) for 11 x 11-inch material (refer to "Options and accessories" later in this manual).

Refer to the table above and to the paragraphs that follow for more information about selecting the best option for your specific needs.

Paper prints

The XLT 7720 printer produces both color and black-and-white prints at a maximum reflection density of 2.5, which satisfies most applications for reflection prints. Paper prints require only a single printing pass, regardless of the ribbon type used. The XLT-100 color ribbon provides a slight speed increase over the XL-100 color ribbon (refer to "Ribbons" later in this section).

Transparencies

The key factor in producing high quality overhead transparencies is obtaining the best maximum optical density. Higher density usually results in higher quality; however, the type of projector used to view the transparencies and the room lighting available should also be considered when determining the most desirable density level setting.

Kodak has conducted human factors research with different types of projectors in varying lighting conditions. The results of this research are summarized in the following paragraphs. Use this information, along with the table on the previous page, to select the appropriate density level for your particular viewing conditions.

- **Double pass overhead projector**—this is usually a portable projector with a light source above the transparency and a mirror below it. The projected light passes through the transparency *twice*.

For high ambient room lighting (natural or artificial lighting at a level that permits comfortable reading from a printed page), the maximum density should be *less than or equal to 1.5* (low-density setting).

A density of greater than 1.5 is not recommended. The projector optics effectively double the density of the transparency and the high ambient light levels diminish the appearance of the dark areas.

- **Single pass overhead projector**—the light source is below the transparency. In this configuration, higher-quality conference room projectors are used.

—For high ambient room lighting, the maximum density should be *greater than or equal to 1.5* (intermediate-, or normal-density settings).

Densities above this level provide equally pleasing results for most transparency subject matter and do not detract from the perceived quality. However, the high ambient lighting diminishes the effect of a higher density setting.

—For darkened rooms (where the principle light source is from the overhead projector), the maximum density should be *greater than or equal to 1.8* (intermediate- or normal-density settings).

NOTE: This setting, combined with other attributes of the XLT 7720 printer and *Kodak Ektatherm™* media, provide “professional quality” overhead transparencies.

This condition is optimal for viewing overheads made on the XLT 7720 printer. Maximum densities above a threshold of 1.8 provide equally pleasing visual results for nearly all subject matter. Higher available densities do not detract from perceived quality, but generally cost more and offer little benefit.

- **Backlit view box**—For backlit displays, the maximum density should be *greater than 2.5* (high-density setting). *Kodak Ektatherm* transparencies are excellent for use in these displays.

Ribbons

The new high-efficiency XLT 100-C color ribbon has been developed exclusively for the XLT 7720 printer. It enables you to produce professional quality overhead transparencies with a single printing pass (with the intermediate-density setting). This saves both time and materials, when compared to the XL 100C color ribbon (for a comparable density setting). Additionally, the new ribbon doubles, from 50 to 100, the number of professional quality transparencies that can be produced with a single ribbon cartridge.

The standard efficiency XL 100-C (color) and XL 300-B (black-and-white) ribbons can also be used in the XLT 7720 printer. These ribbons produce the same excellent prints and transparencies from the XLT 7720 printer that are available from the XL 7700 printer.

The *high* efficiency color ribbon should generally be used if your primary output is transparencies, with prints being made on an occasional basis. The *standard* efficiency color ribbon should generally be used if your primary output is paper prints.

If you are outputting large volumes of both transparencies *and* paper prints, the most cost-effective strategy may be to alternate between the two types of ribbons.

Installing the XLT 7720 printer

Installing the side panel or rack and slide mount kits

The XLT 7720 printer may be configured for integration into numerous operating environments. The table-top configuration is tailored for workstation use. The printer can also be rack-mounted for more lab-oriented applications. You must install either the *Kodak XLT Printer Tabletop Side Panel Kit/XLT 7050* or the *Kodak XLT Printer Rack and Slide Mount Kit/XLT 7052*.

Unlocking the drum assembly

To prevent damage to the printer during shipping, two screws hold its drum assembly in place. You must remove these screws before you operate the printer or install a ribbon cartridge.

NOTE: If the printer is shipped to another location, first remove the ribbon cartridge and secure the drum with the two screws.

1. Remove the red-colored drum locking screw from *both* the right-hand and left-hand walls of the printer drum assembly.

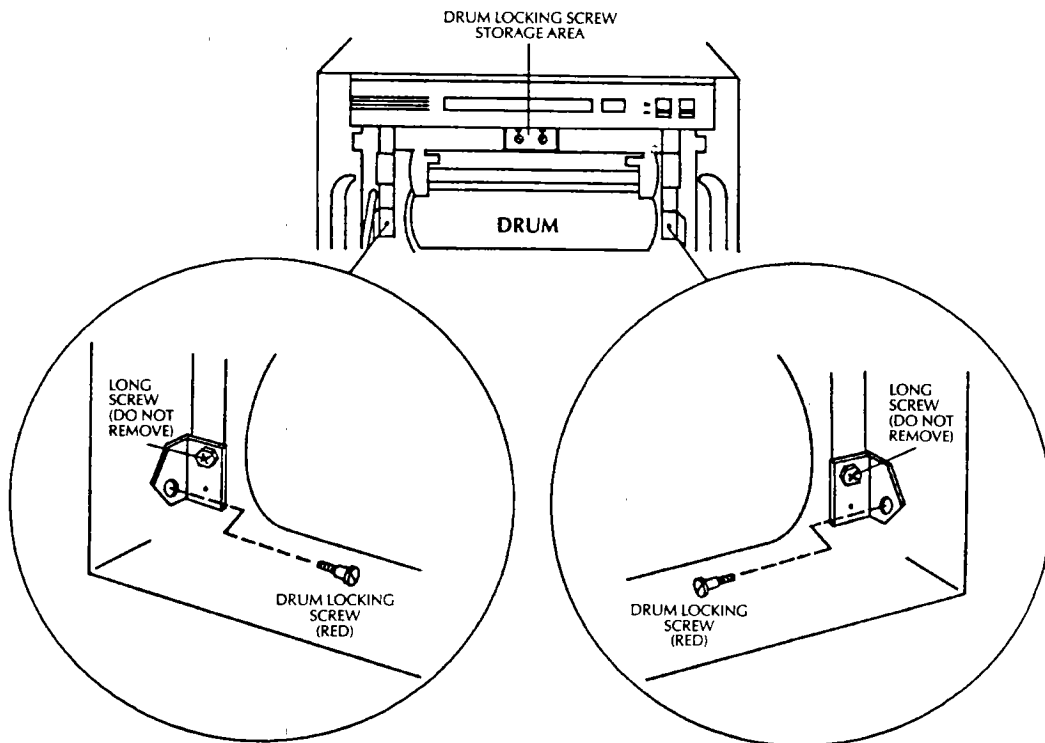

CAUTION: Do not unfasten the long screw located near each locking screw or else the drum assembly will become misaligned.

2. Save the locking screws in case you ever need to repack the printer for shipping. The screws can be conveniently stored by installing them in the drum locking screw storage area, as shown in the preceding illustration. If the screws become misplaced, substitute a standard #8-32 x 3/16-inch shoulder screw.

Line voltage conversion

The Kodak XLT 7720 printer is shipped from the factory for operation at 120 V AC as shown in the following illustration. If your operating voltage is 100 volts, 220 volts, or 240 volts, a line voltage conversion is required before you begin to operate your printer. (The "Read Me First" package includes an adhesive label that lists the various operating voltage options. The appropriate portion of this label should be affixed to the power supply if you change the operating voltage.)

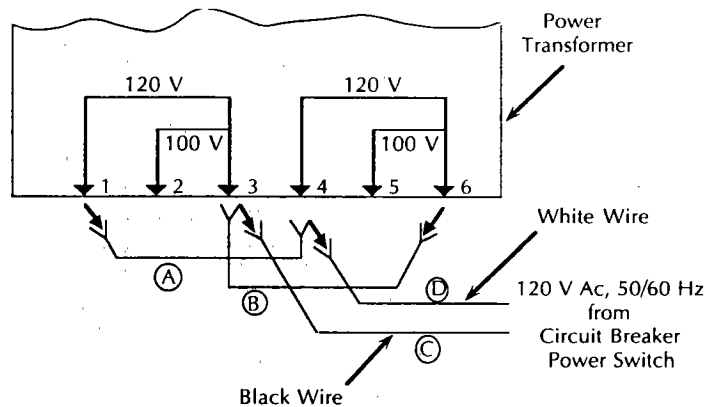

120 V AC configuration

Line voltage conversion is required if you will use 100, 220, or 240 V AC to operate your printer. Use one of the following conversion procedures appropriate for your line voltage.

WARNING: *Line voltage conversion (transformer jumper changes) must be done by a qualified service technician.*

100 V AC line conversion

To convert from 120 V AC to 100 V AC:

1. Set the printer's power switch to the off (O) position.
2. Disconnect the 120 V AC power cord (supplied with the printer) from the rear of the printer.
3. Locate and remove the seven mounting screws holding the lower rear printer cover in place. Remove the cover and set it aside with the screws.
4. Refer to the 120 V AC configuration illustration at the beginning of the "Line voltage conversion" section above. Disconnect wire A from transformer lug 1 and connect it to transformer lug 2 as shown in the following illustration:

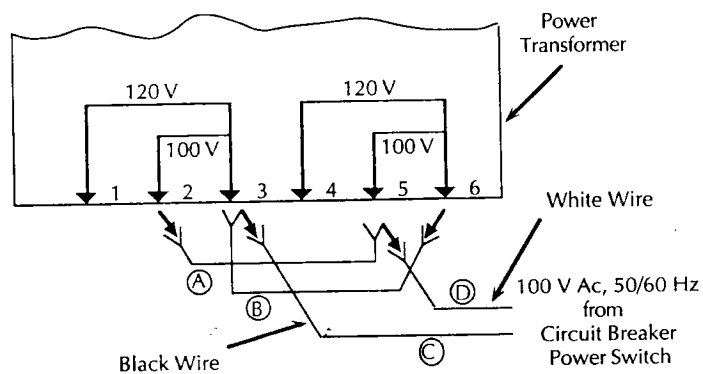

100 V AC configuration

5. Disconnect wires A and D from transformer lug 4 and connect them to transformer lug 5.

CAUTION: Before replacing the cover on the rear of the printer, check the transformer connections again. Mistakes could damage the printer.

6. Install the lower rear printer cover with the mounting screws removed in step 3.
7. Remove the 120 V AC 60 Hz adhesive label from the lower rear printer cover (above the power cord connector) and replace it with the 100 V AC 50/60 Hz portion of the adhesive label (Pt. No. 783755). (The adhesive label is in the "Read Me First" package.)

CAUTION: Do not use the 120 V AC cord supplied with the printer.

8. Install the power cord (supplied locally) required for a 100 V AC power source.

220 V AC line conversion

To convert from 120 V AC to 220 V AC:

1. Set the printer's power switch to the off (O) position.
2. Disconnect the 120 V AC power cord (supplied with the printer) from the rear of the printer.
3. Locate and remove the seven mounting screws holding the lower rear printer cover in place. Remove the cover and set aside with the screws.
4. Locate the terminal block on the 5 V DC supply (at the extreme right rear of the printer). Remove the transparent cover over the terminal block. Remove the jumper from the terminal block, as shown in the following illustration, and replace the transparent cover.

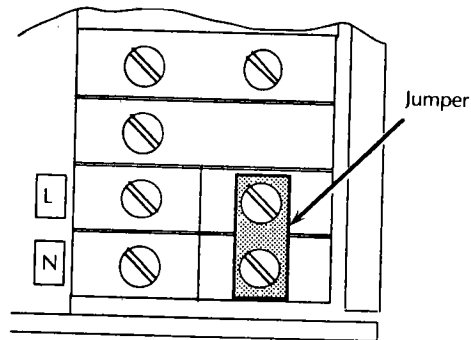

NOTE: Save the jumper and screws you removed if the printer will be converted to another voltage in the future.

5. Refer to the 120 V AC configuration illustration at the beginning of the "Line voltage conversion" section above. Disconnect wires C and D from transformer lugs 3 and 4, respectively. Remove wires A and B completely from the transformer. Connect wire A between transformer lug 3 and lug 5. Connect white wire D to transformer lug 1 and black wire C to transformer lug 6 as shown in the following illustration:

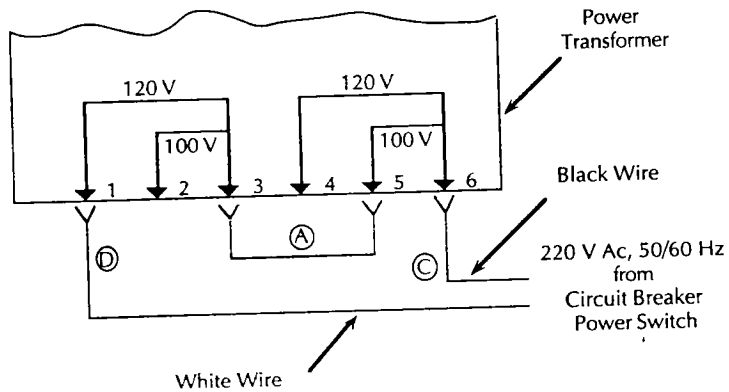

220 V AC configuration

NOTE: Save wire B if the printer will be converted to another voltage in the future.

CAUTION: Before replacing the cover on the rear of the printer, check the transformer connections again. Mistakes could damage the printer.

6. Install the lower rear printer cover with the mounting screws removed in step 3.
7. Remove the 120 V AC 60 Hz adhesive label from the lower rear printer cover (above the power cord connector) and replace it with the 220 V AC 50/60 Hz portion of the adhesive label (Pt. No. 783755). (The adhesive label is in the "Read Me First" package.)

CAUTION: Do not use the 120 V AC cord supplied with the printer.

8. Install the cordset (Pt. No. 476324) or locally supplied power cord required for a 220 V AC, 5 amp load.

240 V AC line conversion

To convert from 120 V AC to 240 V AC:

1. Set the printer's power switch to the off (O) position.
2. Disconnect the 120 V AC power cord (supplied with the printer) from the rear of the printer.
3. Locate and remove the seven mounting screws holding the lower rear printer cover in place. Remove the cover and set it aside with the screws.
4. Locate the terminal block on the 5 V DC supply (at the extreme right rear of the printer). Remove the transparent cover over the terminal block. Remove the jumper from the terminal block (refer to the illustration in "220 V AC line conversion" above) and replace the transparent cover.

NOTE: Save the jumper and screws you removed if the printer will be converted to another voltage in the future.

5. Refer to the 120 V AC configuration illustration at the beginning of the "Line voltage conversion" section above. Disconnect wires C and D from the transformer. Remove wires A and B completely from the transformer. Connect wire A between transformer lug 3 and lug 4. Connect white wire D to transformer lug 1 and black wire C to transformer lug 6 as shown in the following illustration:

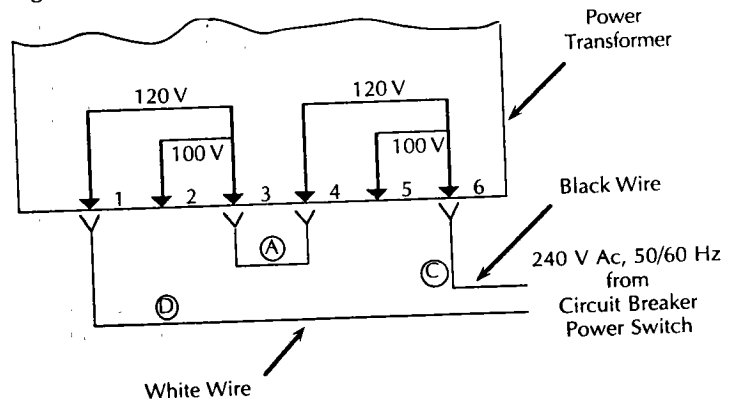

240 V AC configuration

NOTE: Save wire B if the printer will be converted to another voltage in the future.

CAUTION: Before replacing the cover on the rear of the printer, check the transformer connections again. Mistakes could damage the printer.

6. Install the lower rear printer cover with the mounting screws removed in step 3.
7. Remove the 120 V AC 60 Hz adhesive label from the lower rear printer cover (above the power cord connector) and replace with the 240 V AC 50/60 Hz portion of the adhesive label (Pt. No. 783755). (The adhesive label is in the "Read Me First" package.)

CAUTION: Do not use the 120 V AC cord supplied with the printer.

8. Install the cordset (Pt. No. 476324) or locally supplied power cord required for a 240 V AC, 5 amp load.

Computer interface options

Your XLT 7720 printer includes either an IEEE 488 or SCSI interface. The model designation on the printer's data plate (located on the lower rear cover) indicates the applicable interface: XLT7720-CI for IEEE 488 and XLT7720-CS for SCSI.

If your printer has a SCSI interface, you were also provided with a cable that has a 50-pin male micro-ribbon connector on each end. If your host computer requires a different type of connector, you will need an adaptor or an alternate cable to connect the printer to your computer. Such a cable may be available locally or from your system supplier. For additional information, contact your system supplier or Kodak Customer Technical Support.

NOTE: You can convert from an IEEE 488 to a SCSI configuration (or vice versa) by installing the appropriate interface conversion kit, which is available from your dealer (refer to "Options and accessories" later in this manual).

Connecting to the host computer

Specific cabling between your computer and the XLT 7720 printer are dependent on the type of computer interface, IEEE 488 or SCSI, as well as on the type of computer. Refer to the manual supplied with your printer driver software for instructions for connecting the printer to the host computer.

Installing printer driver software

In addition to the computer interface (IEEE 488 or SCSI), there must be a software "driver" resident in the host computer that manages communications between the printer and the computer. This software "driver" is specific to the computer interface, the host computer operating system (Mac OS, UNIX, DOS, etc.), and the specific computer model. This driver program is not supplied with the printer; it must be procured separately from the supplier of your system and installed in your host computer or workstation. Refer to the manual supplied with your printer driver software for instructions to install this software.

Using the XLT 7720 printer

Controls and indicators The following paragraphs describe the controls and indicators of the XLT 7720 printer.

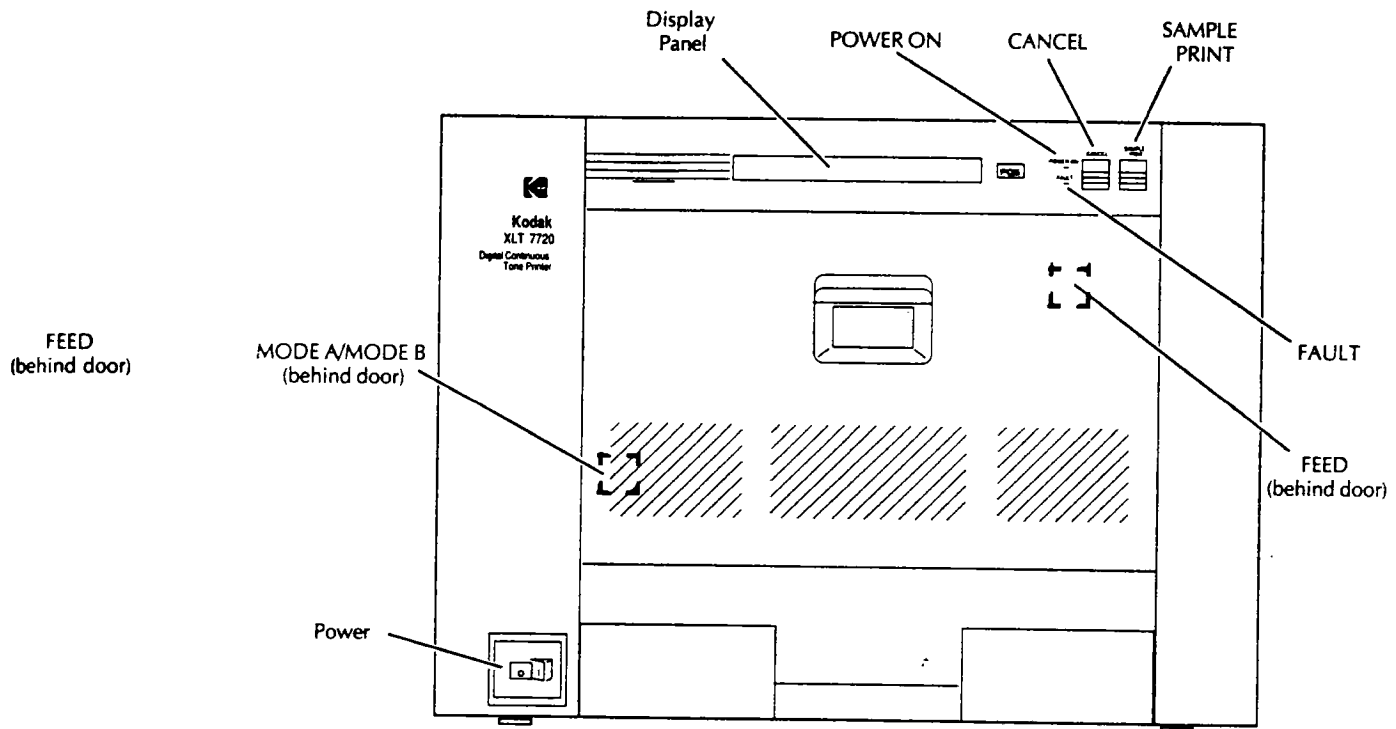

Power switch. This switch controls power to the printer and serves as its main circuit breaker.

Display panel. A liquid crystal display on the front of the printer incorporates two 40-character lines of text to advise you of printer status or alert you to printer errors. See the "Powering up" and "Troubleshooting" sections of this manual for examples of panel displays.

POWER ON indicator. The **POWER ON** indicator lights when power is applied to the printer.

FAULT indicator. The **FAULT** indicator lights when an error condition exists.

CANCEL button. The **CANCEL** button serves the same function as an "abort" command from the host computer. Pressing the **CANCEL** button instantly terminates any operation in progress; i.e., stops the downloading of a digital image file or any portion of a printing cycle or printer initialization sequence. The printer then ejects any picture in process and assumes an initialized state. **CANCEL** does not affect any parameter values or image data stored in the printer; **CANCEL** does set the error bit in the printer status byte and activates the cancel error mode.

When the printer door is open, pressing the **CANCEL** button moves the drum surface in a downward direction until the button is released. This is a convenient aid if a jam occurs.

SAMPLE PRINT button. You may generate a predetermined sample print by pressing the **SAMPLE PRINT** button. *This print is intended to check the printer operation only and is not calibrated.* It will appear to have different colors and densities with different print material and modes.

When the front door is open, the **SAMPLE PRINT** button rotates the drum upward until the button is released. This is a convenient aid if a jam occurs in the printer.

MODE A/MODE B switch. This rocker switch, mounted inside the printer door and to the left side, allows you to select the printing mode that is best suited to the type of image you want printed. Mode A is the normal printing mode. Use Mode B to print images that contain a high-contrast inset, such as an annotation label or to print business graphics images. To use a different mode setting, you must change the switch position before sending a print request.

NOTE: All A4-size prints are automatically printed in Mode B, regardless of the position of the switch.

FEED button. Press the red **FEED** button, located inside the door and to the right, to activate the paper advance rollers. These rollers transport the paper or transparency material from the tray to the drum. The rollers will turn as long as the **FEED** button is depressed. *Simultaneously* press the **FEED** and **SAMPLE PRINT** buttons to clear the paper path of any jams.

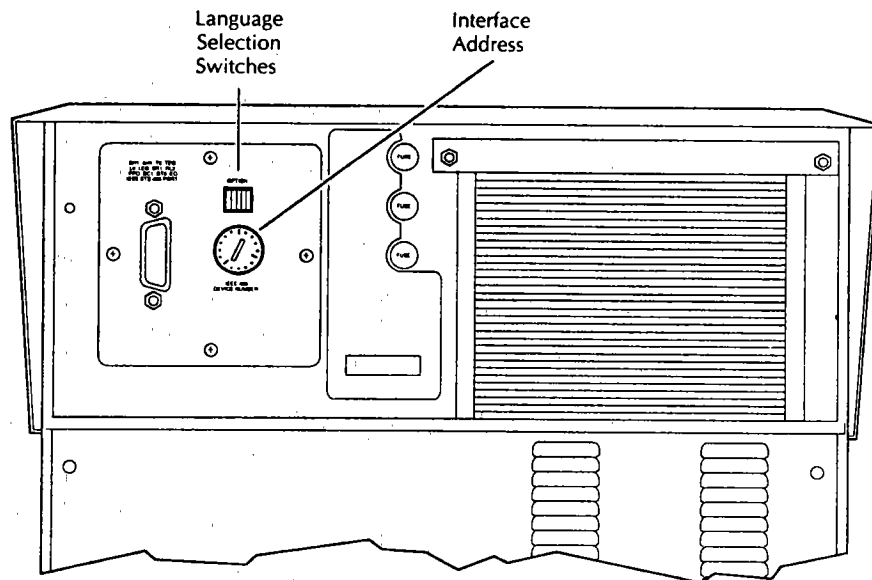

Interface address. A switch at the rear of the printer allows you to select the unique address for the printer on the particular interface bus used (IEEE 488 or SCSI):

- **IEEE 488.** Set the rotary switch on the interface plate or board to a position that corresponds to the printer's address on the IEEE 488 bus.
- **SCSI.** Set the rotary switch on the SCSI interface plate or board at the rear of the printer to an address between 0 and 7. This address must not be currently used by another device on the SCSI bus. (Numbers higher than 7 will not be recognized by the host computer.)

Language selection switches. Four dip switches at the rear of the printer allow messages to be displayed on the printer's front display panel in any one of five languages, when set as shown below.

Language	Dip Switch Settings			
	(MSB)	1	2	3
English	0	0	0	0
French	0	0	0	1
Spanish	0	0	1	0
Italian	0	0	1	1

NOTE: "0" = OFF "1" = ON

Powering up

The XLT 7720 printer performs a self-test initialization routine each time the unit is powered up. The front panel displays the following series of messages during this "health check" to verify proper initialization.

```
COPYRIGHT EASTMAN KODAK, - 1989.  
ALL RIGHTS RESERVED.*****
```

```
SELF TEST*****  
PRINT COUNT 000000000000 C-XX.XX S-XX.XX
```

C-XX.XX is the CPU firmware version and S-XX.XX is the SCSI firmware version (for SCSI printers only).

```
BUSY
```

The printer displays the word **BUSY** when it cannot respond to commands from the host computer or to the control switches on the printer. This indicates that the printer is currently doing a task such as processing an image.

After initialization, **READY** is displayed and the printer is ready to begin printing. The display also indicates the size and type of the print material installed, as well as the ribbon type in use.

```
READY      SIZE      TYPE      RIBBON  
           11.0      P        COLOR1
```

SIZE = **11.0, 8.5 or A4**

TYPE = **P or T**

RIBBON = **COLOR1** (XL 100-C), **COLOR2** (XLT 100-C),
BLACK (XL 300-B), or * (unknown)

From a cold start, the print head requires a maximum of 10 minutes to warm up. During this time, the printer accepts all commands from the host computer. If the printer receives a print command, it accepts the command but does not begin printing until warmup is completed.

Making a sample print

The sample print function makes a print, even when the printer is not connected to a host computer.

NOTE: The sample print is not calibrated and should not be used as a reference for image quality. Calibrated prints can be obtained via the host computer.

At any time after power up and initialization, you can make a sample print by pressing the **SAMPLE PRINT** button. This produces a checkered print that includes the date, the time, and the sequence number (quantity of prints or transparencies made since the date of printer manufacture) at the center bottom of the page. This data is displayed in the selected language.

Installing the Kodak Ektatherm ribbon cartridge

To install a *Kodak Ektatherm* ribbon cartridge:

1. Open the front door by raising the latch and pull the door forward.

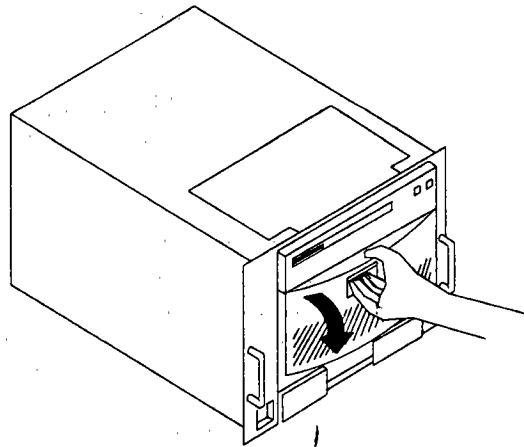

2. Note the three locator pins on the right, the middle pin, and the two sprockets on the left.

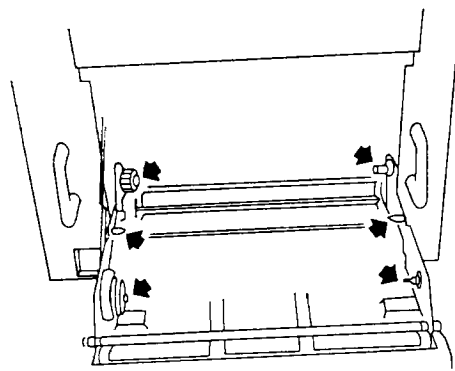

3. Remove any slack in the ribbon. Orient the ribbon with the labeled end facing you.

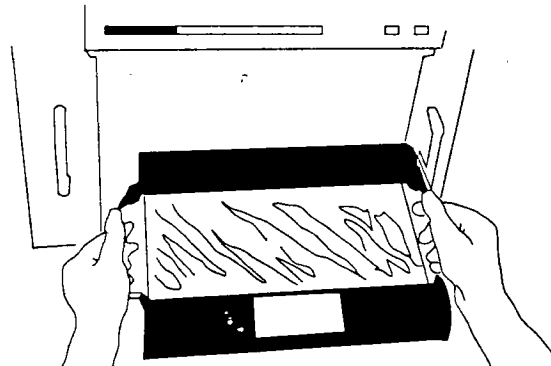

4. Align the rear, middle, and then the front locator pins on the right side.

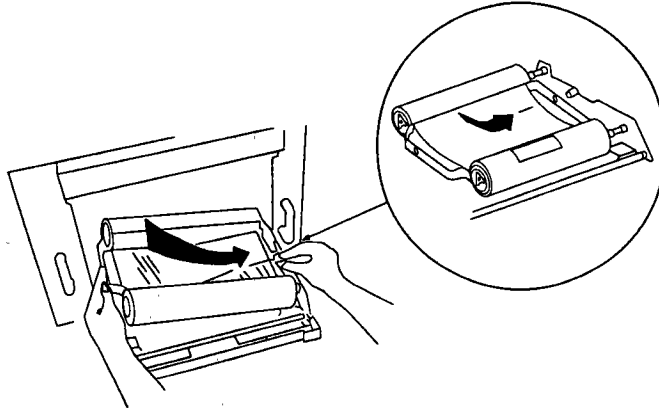

5. Slide the cartridge to the right to engage the sprockets and middle pin on the left.

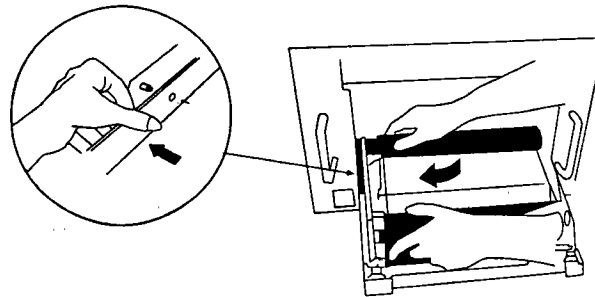

6. Close the door securely.

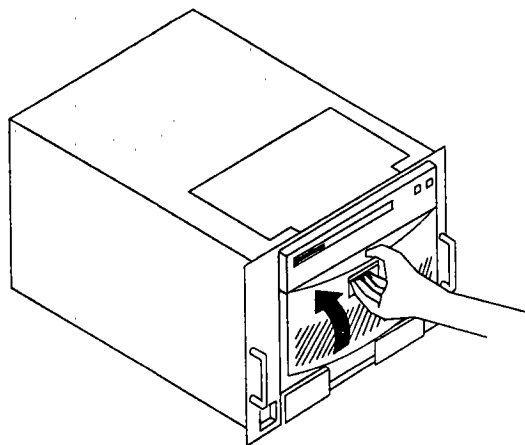

Loading *Kodak Ektatherm* print paper or transparency material

To load the print materials:

1. Pull out the lower supply door.

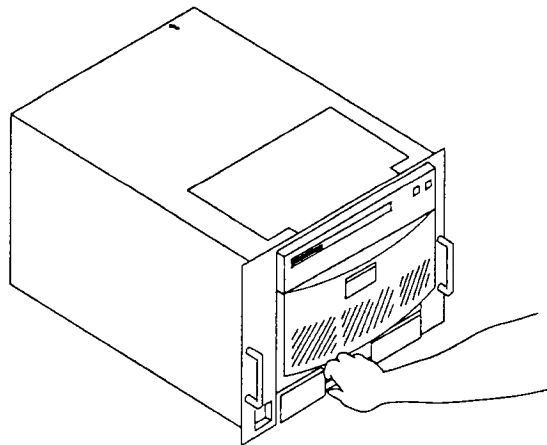

2. Discard the stiffener from the previous loading. Lift out the tray.

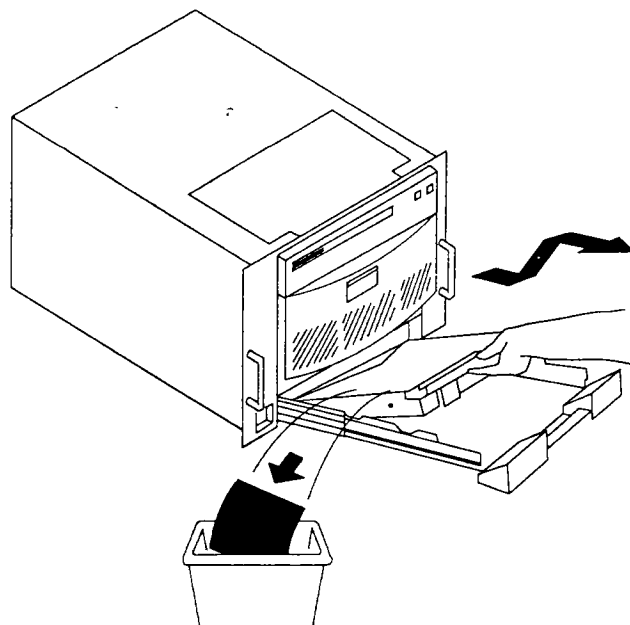

3. To adjust the tray size, press the buttons on the back.

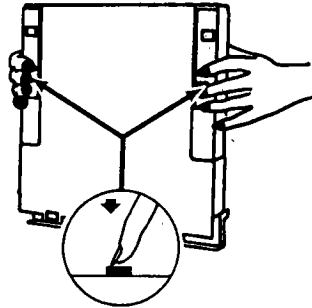

4. Slide the tray guide to fit the paper size.

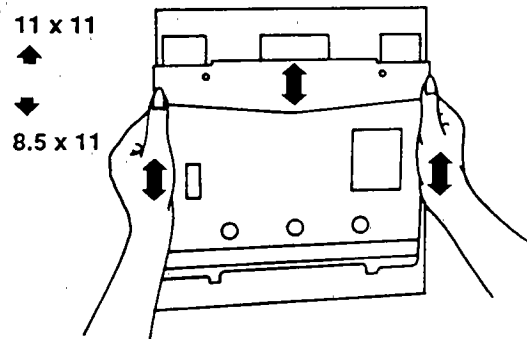

5. Slide the paper or transparency material with the top and bottom stiffeners under the guide.

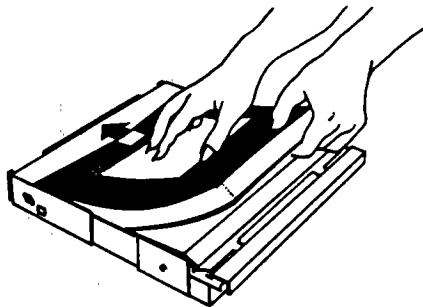

6. Remove the top stiffener.

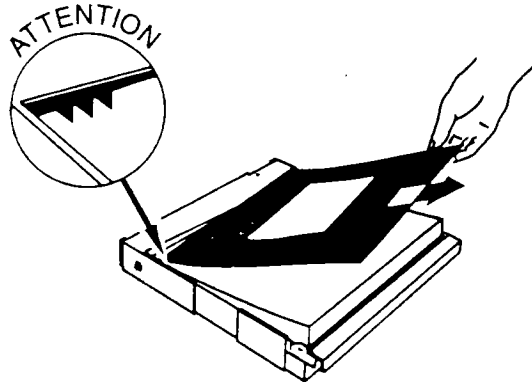

7. Check that the paper or transparency material is loaded face down and that it is oriented correctly in the tray:
 - **Paper** (all sizes)—the printing on the paper should be right-reading.
 - **Transparencies**—the notches should be in the left corner of the *top edge* of the transparency material.
8. Pivot the clips outward while pressing the paper or transparency material downward. Release the clips.

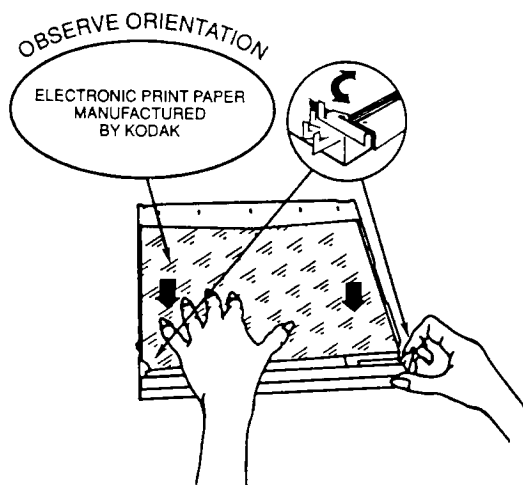

9. Place the loaded tray into the supply drawer.

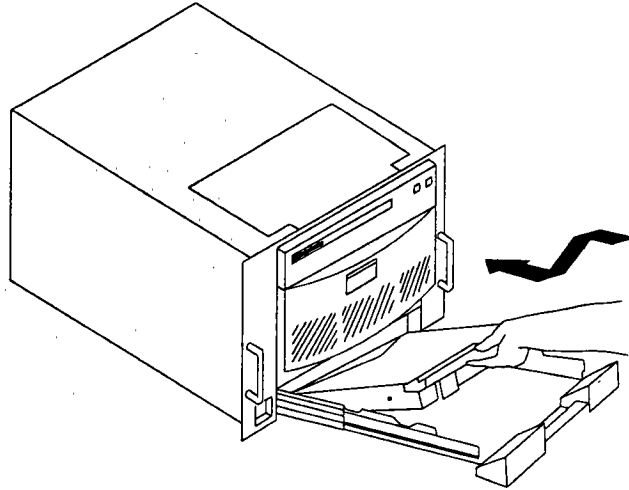

10. Close the drawer securely.

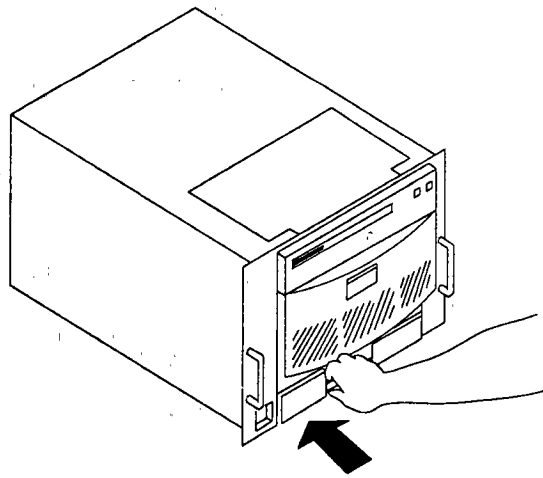

Handling your *Kodak Ektatherm* products

General

The major enemy of good printer performance and high-quality output is dirt. Always keep your work area and material storage area as clean as possible.

Replace the air filter every 600 hours of operation or once a year, whichever comes first. Refer to "Replacing the air filter" later in this manual.

Ribbon cartridges

- Store unopened ribbon cartridges at temperatures below 86° F (30° C) at any relative humidity. See storage instructions on the package.
- Do not expose the ribbon cartridge to direct sunlight or extreme heat, dust, liquids, etc. For protection, store the unpackaged ribbon cartridge in the *Kodak XL Printer Ribbon Cartridge Protector/XL 7042*.

Paper prints and transparencies

CAUTION: Some sleeves used for print storage may adversely affect the dyes used in *Kodak Ektatherm* products. Avoid PVC (polyvinyl chloride) sleeves—they are easily identified by their distinctive "plastic" odor. Use archival quality sleeves made of *Mylar™* material, polypropylene, or polyethylene.

- To safeguard image stability, keep the prints in a cool, dry environment. Avoid exposure to direct sunlight or bright direct lighting.
- Avoid print cleaning chemicals labeled "for use with silver halide prints." They may adversely affect the dye used in *Kodak Ektatherm* products.

Paper and transparency material

- Store unopened paper or transparency material at temperatures below 86° F (30° C) at any relative humidity. See storage instructions on the package.
- For best results, store opened paper or transparency material at temperatures no greater than 72° F (22° C) and at relative humidity levels from 40 to 60%.
- For best results in transporting transparency material through the printer, do not expose the material to relative humidity greater than 65% for more than 48 hours. To accomplish this, you may want to limit printer loading to one day's usage.
- Paper will swell slightly at relative humidities exceeding 65%. If this occurs when the paper tray is full, the printer may be unable to transport the paper. We recommend that you divide the 100-sheet stacks into two stacks of about 50 sheets and load them separately when operating under high humidity conditions. Be sure to add a stiffener board to the bottom of the divided stack.
- Before loading paper or transparency material into the paper tray, fan it as though leafing through a book.
- To avoid fingerprints on the printing surface of the paper or transparency material, be sure to retain the top and bottom stiffener boards as they are packaged.
- Do not use wet or damaged stock.
- When installing the paper or transparency material with both stiffener boards in place, ensure that:
 - Paper has been loaded with the face down. (Please note the label on the stiffener board.)
 - The printing on the back of the paper is right reading.
 - Transparencies are loaded with the code notches oriented to the rear edge, left-hand corner of the supply drawer.
 - Top stiffener board is removed.

CAUTION: Failure to properly orient the paper or transparency material may result in printer malfunction and printer jams. Please read the instructions in "Loading *Kodak Ektatherm* print paper or transparency material."

Clearing jams in the printer

Occasional jams in the printer's feed path may occur and do not necessarily indicate a serious printer problem. The XLT 7720 printer has three user's aids to facilitate clearing these jams: the dual-purpose **SAMPLE PRINT** and **CANCEL** buttons and the **FEED** button. Push both the **SAMPLE PRINT** and **FEED** buttons with the printer's front door open. The print drum will rotate upward to expel the material. Push the **CANCEL** button with the front door open and the print drum will rotate downward to back out the material.

Clearing a jam in the print tray

1. Open the front door.
2. Press the **SAMPLE PRINT** and **FEED** buttons. Hold them down until the material is free.

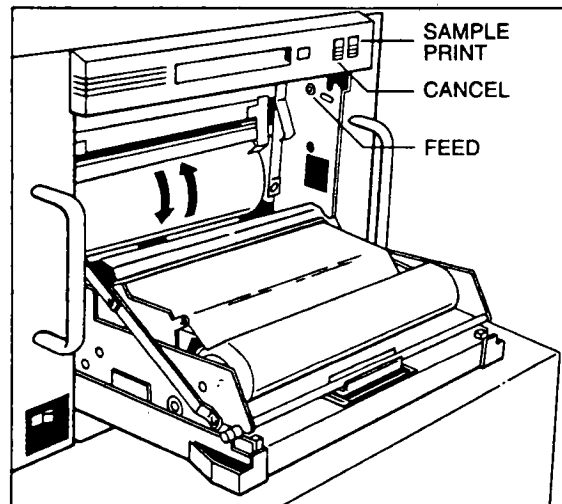

3. Examine the print material for damage; discard any damaged stock.
4. Open the paper tray; examine contents for damage. Reload as necessary.

Clearing material on the print drum under error conditions

1. Open the printer's front door.
2. Push the **SAMPLE PRINT** button. Hold it down until the material is free.
3. Close the front door and remake the print.

Clearing a jam in the finishing station

WARNING: *The finisher reaches temperatures over 200° F (93° C). Read and follow all warning labels on printer surfaces.*

WARNING: *The printer weighs approximately 130 pounds (59 kg). This can present a hazardous situation when the printer is extended from its rack on rack slides. To prevent the rack from overturning, be sure to anchor it to a sturdy foundation or provide the rack with outrigger legs.*

1. Open the access cover on the top surface of the printer by loosening its two quarter-turn fasteners.
2. Release the two fasteners on the right side of the finisher and remove the finisher's top cover.

CAUTION: **Take care to avoid damage to the finisher components when extracting material from the printer.**

3. Open the front door. Push the **CANCEL** button to eject the jammed material through the top of the printer. Pulling the material to assist in extraction is permissible. If you cannot access the jammed material, do step 4.
4. Push the **SAMPLE PRINT** button to eject the material through the front door. Pushing the material inward to assist in ejection is permissible. Remove material from the print drum as described above.
5. If the print material wasn't wound onto the printing drum during step 4, close and reopen the door. Then repeat step 3.

Maintaining the printer

Good housekeeping

- All rules of general good housekeeping that apply to photographic or electronic equipment, in general, apply to the XLT 7720 printer. Keep the printer and surrounding area vacuumed and litter free. Do not expose the printer to tobacco smoke or potential liquid spills. Do not pile objects on top of the printer.
- When storing the XLT 7720 printer, keep the front door and paper tray closed, and disconnect all cabling. Store nothing on top of the printer.
- For long-term storage, we recommend that you put the printer into its original packaging.

Cleaning the print head

For best results, clean the print head whenever you load a new ribbon cartridge.

To clean the print head:

1. Open the front door.
2. Remove the *Kodak Ektatherm* ribbon cartridge.

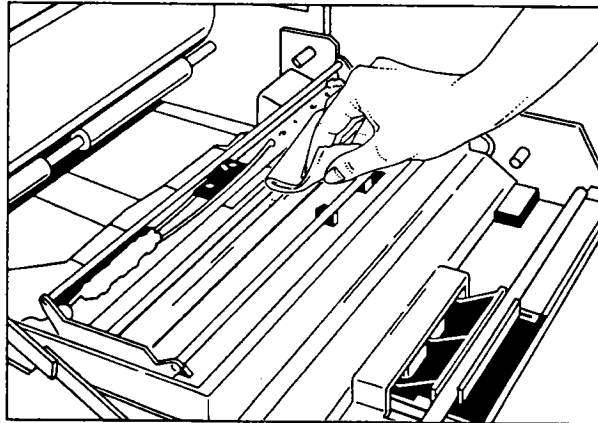

3. Remove any foreign materials using a clean, lint-free cloth dampened with acetone solvent, which can be purchased at most hardware stores. If it is not available, you may use isopropyl alcohol.
4. If any foreign matter adheres to the print head, scrape the head lightly with a soft, non-metallic object such as a coffee stirrer.

CAUTION: Do not use sharp objects to clean the thermal print head.

Replacing a fuse

The power switch serves as the main circuit breaker for the printer. In addition, three fuses, located on the back of the XLT 7720 printer, protect the printer in case of current overloads or short circuits. A 5-amp fuse protects the head preheat circuit; two 10-amp fuses protect the finisher heater and the print head. All three are labelled to show proper fuse ratings and the circuits they protect.

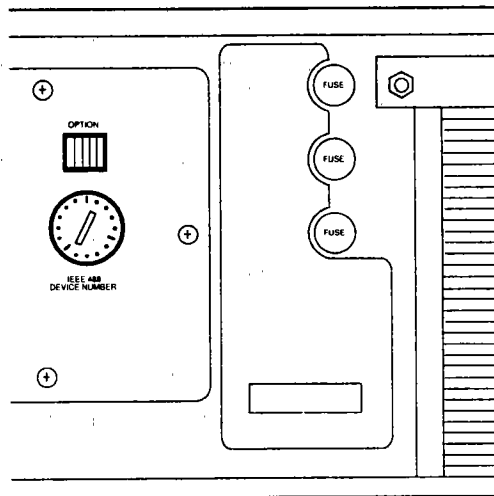

To replace a fuse:

1. Turn off the printer.
2. Disconnect the power cord.
3. Remove the fuse holder.
4. Remove the fuse. Replace it with the following:
 - Head preheat circuit—Type 3AB ceramic body, 1/4 x 1/4-inch, normal blow, 5-amp, 250-volt (*Littlefuse* #217005, or equivalent).
 - Finisher heater or print head—type 3AB ceramic body, 1/4 x 1/4-inch, normal blow, 10-amp, 250-volt (*Littlefuse* #314010, or equivalent).

Replacing the air filter

The air filter must be replaced after 600 hours of printer "on" time or one calendar year, whichever comes first. To replace the air filter:

1. Loosen the two #8 screws which secure the filter retainer to the back of the printer.

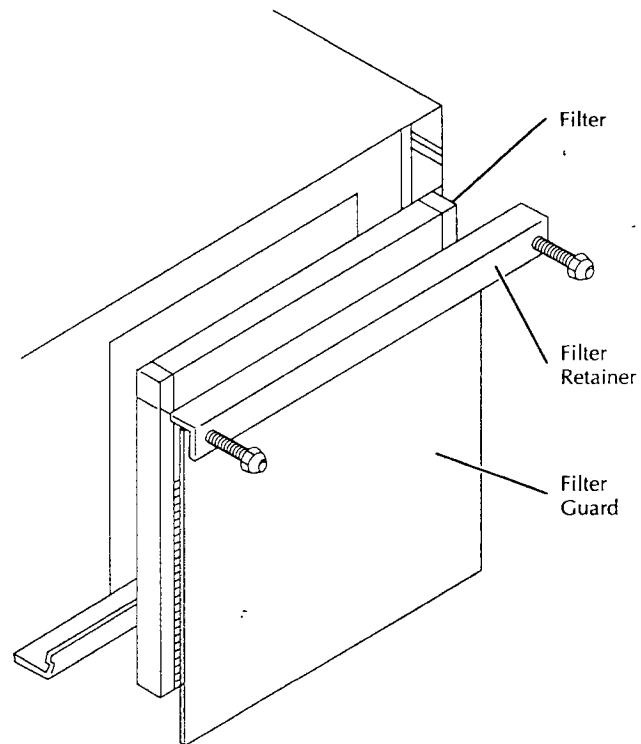

2. Pull the filter retainer off the #8 screws.
3. Lift the dirty filter up and away from the printer.
4. Set the new filter into the shallow channel beneath and between the studs. Make sure the foam rubber gasket faces the rear of the printer cabinet.
5. Replace the filter retainer.
6. Tighten the #8 screws.

Replacing the battery

The main CPU board uses a high-capacity lithium battery for the real time clock to retain the correct time, date, and computer parameters while the printer is turned off. This battery should last approximately four years. When the battery needs replacement, contact a qualified service technician.

NOTE: An expired battery is signaled by error code 153 (See "Troubleshooting").

Troubleshooting

Before requesting service, you may be able to correct or identify the problem yourself. Locate the fault condition and code (as displayed on the printer front panel or at the host computer) on this chart below, then follow the suggested procedure.

Code: 134

Display message: UNFINISHED PRINT
OPEN DOOR TO RESET

Probable cause: Finisher too hot or too cool with print in unit.

Corrective action: Open door, clear print from mechanism by pressing **SAMPLE PRINT** button until end of paper is visible. Grasp end of paper, press **CANCEL** button until clamp opens, releasing paper from drum.

Open door and close to reset. If error persists, turn printer power off. Wait several minutes, turn power on. If error returns, check finisher fuse on rear of unit, replace if necessary and restart unit. If fuse blows again or an error recurs, call Service.

Code: 138

Display message: REINSTALL PAPER TRAY
OPEN DOOR TO RESET

Probable cause: Two mutually exclusive print material size/tray sensors activated simultaneously.

Corrective action: Check the paper tray. Verify that the tray and print material installed agree with those shown on the printer's front panel display. Check the area behind the paper tray for stray pieces of paper. Install the paper tray, and then open and close the door to reset.

Code: 139

Display message: CHECK RIBBON AND PAPER
OPEN DOOR TO RESET

Probable cause: (1) Small paper or transparency installed but image requires large size.
(2) Wrong type ribbon for print requested.
(3) Wrong color ribbon installed for printer configuration.
(4) Ribbon or print material has been changed after a print request has been issued.

Corrective action: (1) Check tray and load correct or type.
(2) Open door and check for correct ribbon.
(3) Open door and check for correct color ribbon.
(4) Open door and check for correct ribbon. Check tray and load correct material.
(5) To clear an error without changing the print material or ribbon, press **SAMPLE**; then open and close the door.

Code: 144

Display message: RIBBON ADVANCE ERROR
YELLOW/CLEAR-OPEN DOOR TO RESET

Probable cause: (1) Ribbon not advancing.
(2) Black ribbon installed in color cartridge.

Corrective action: (1) Open door, check cartridge for proper installation. Inspect ribbon and cartridge for damage.
(2) Replace with color ribbon.

Code: 145

Display message: RIBBON ADVANCE ERROR
MAGENTA-OPEN DOOR TO RESET

Probable cause: (1) Ribbon not advancing.
(2) Black ribbon installed in color cartridge.

Corrective action: (1) Open door, check cartridge for proper installation. Inspect ribbon and cartridge for damage.
(2) Replace with color ribbon.

Code: 146

Display message: RIBBON ADVANCE ERROR
CYAN/BLACK-OPEN DOOR TO RESET

Probable cause: (1) Cartridge not installed.
(2) Ribbon not advancing.

Corrective action: (1) Open door, install cartridge.
(2) Open door, check cartridge for proper installation. Inspect ribbon and cartridge for damage.

Code: 147

Display message: OUT OF RIBBON
REPLACE RIBBON

Probable cause: (1) Out of ribbon.
(2) Ribbon not advancing.
(3) Ribbon stuck to drum or print.

Corrective action: (1) Open door, install cartridge.
(2) Open door, check cartridge for proper installation. Inspect ribbon and cartridge for damage.
(3) Open door, clear print, and rewind slack ribbon into take-up spool.

Code: 148

Display message: RIBBON MOTION SENSOR
OPEN DOOR TO RESET

Probable cause: (1) Unexpected ribbon motion.
(2) Sensor or circuit malfunction.

Corrective action: (1) Open door, check cartridge for proper installation. Inspect ribbon and cartridge for damage.
(2) Call Service.

Code: 153

Display message: WARNING BATTERY EXPIRED
OPEN DOOR TO RESET

Probable cause: (1) Battery expired.
(2) CPU jumper not set up.

Corrective action: (1) Call Service.
(2) Call Service.

Code: 160

Display message: PAPER JAM-FEED-OPEN DOOR
HOLD FEED-PUSH SAMPLE PRINT

Probable cause: Paper or transparency at clamp.

Corrective action: Open door, use **FEED** button to drive paper out while using **SAMPLE PRINT** button to rotate drum in the upward direction. See "Clearing jams in the printer."

Code: 161

Display message: PAPER JAM-DRUM-OPEN
DOOR-PUSH SAMPLE PRINT BUTTON

Probable cause: Print still at finisher entrance.

Corrective action: Turn printer power off, open top door, remove finisher lid and clear print. See "Clearing jams in the printer."

Code: 162

Display message: PAPER JAM-FINISHER
CLEAR THROUGH TOP ACCESS

Probable cause: (1) Print jam in finisher.
(2) Exit switch malfunction.

Corrective action: (1) Turn printer power off, open top door, remove finisher lid and clear print. See "Clearing jams in the printer."
(2) Call Service.

Code: 163

Display message: PAPER JAM-FINISHER
CLEAR THROUGH TOP ACCESS

Probable cause: (1) Print(s) remaining in exit chute.
(2) Print jam in finisher.

Corrective action: (1) Remove print(s), open and close door and continue.
(2) Turn printer power off, open top door, remove finisher lid and clear print. See "Clearing jams in the printer."

Code: 164

Display message: PAPER JAM-FEED-OPEN DOOR
HOLD FEED-PUSH SAMPLE PRINT

Probable cause: (1) Paper or transparency not clamped to drum.
(2) Paper motion sensor failure.

Corrective action: (1) Open door, use **FEED** button to drive paper out while using **SAMPLE PRINT** button to rotate drum in the upward direction. Remove and check tray if necessary. See "Clearing jams in the printer."
(2) Call Service.

Code: 165

Display message: OUT OF PAPER-ADD
PAPER-OPEN DOOR TO RESET

Probable cause: (1) Tray empty.
(2) Paper or transparency not reaching clamp.
(3) Clamp switch malfunction.

Corrective action: (1) Remove and refill tray with paper or transparencies.
(2) Open door, use **FEED** button to drive paper out while using **SAMPLE PRINT** button to rotate drum in the upward direction. Remove and check tray if necessary. See "Clearing jams in the printer."
(3) Call Service.

Code: 166

Display message: PAPER JAM-DRUM-OPEN
DOOR-PUSH SAMPLE PRINT BUTTON

Probable cause: (1) Print not fed into finisher correctly.
(2) Finisher entrance switch failure.

Corrective action: (1) Open door, clear jam if necessary using front panel buttons. See "Clearing jams in the printer."
(2) Call Service.

Code: 167

Display message: PAPER JAM-FEED-OPEN DOOR
HOLD FEED-PUSH SAMPLE PRINT

Probable cause: (1) Sensor malfunction.
(2) Urge motor stuck on.

Corrective action: (1) Call Service.
(2) Call Service.

Code: 168

Display message: PAPER JAM-DRUM-OPEN
DOOR-PUSH SAMPLE PRINT BUTTON

Probable cause: (1) Print on drum and second sheet at clamp.
(2) Clamp switch or finisher entrance switch malfunction.

Corrective action: (1) Open door, use **FEED** button to drive paper out while using **SAMPLE PRINT** button to rotate drum in the upward direction. Manually remove second sheet. Close door to eject print on drum. Remove and check tray if necessary. See "Clearing jams in the printer."
(2) Call Service.

Code: 169

Display message: PAPER JAM-FEED-OPEN DOOR
HOLD FEED-PUSH SAMPLE PRINT

Probable cause: Paper not clamped.

Corrective action: Open door, use **FEED** button to drive paper out while using **SAMPLE PRINT** button to rotate drum in the upward direction. Remove and check tray if necessary. See "Clearing jams in the printer."

Code: 180

Display message: DRUM MOTION ERROR
OPEN DOOR TO RESET

Probable cause: (1) Drum can't engage because drum is rotated so clamp is too close to head.
(2) Jam or bind in mechanism.
(3) Sensor failure or engage motor not working.

Corrective action: (1) Open door, rotate drum with front panel buttons so clamp is 30 degrees away from head.
(2) Clear jam. Call Service if necessary.
(3) Call Service.

Code: 181

Display message: DRUM MOTION ERROR
OPEN DOOR TO RESET

Probable cause: (1) Drum rotated so clamp is too close to head.
(2) Jam or bind in mechanism.
(3) Sensor failure or engage motor not working.

Corrective action: (1) Open door, rotate drum with front panel buttons so clamp is 30 degrees away from head.
(2) Clear jam. Call Service if necessary.
(3) Call Service.

Code: 182

Display message: DRUM MOTION ERROR
OPEN DOOR TO RESET

Probable cause: (1) Drum not rotating.
(2) Sensor malfunction.

Corrective action: (1) Open door, clear jam if present. Rotate drum using front panel buttons until clamp cannot be seen. Call Service if drum doesn't move. If it moves, close door and continue.
(2) Call Service.

Code: 183

Display message: DRUM MOTION ERROR
OPEN DOOR TO RESET

Probable cause: (1) Drum not rotating.
(2) Sensor malfunction.

Corrective action: (1) Open door, clear jam if present. Rotate drum using front panel buttons until clamp cannot be seen. Call Service if drum does not move. If drum moves, close door and continue.
(2) Call Service.

Code: 190

Display message: UNABLE TO DETECT LINE
FREQUENCY-OPEN DOOR TO RESET

Probable cause: (1) Line frequency out of spec.
(2) Circuit malfunction.

Corrective action: (1) Connect printer only to proper power source.
(2) Call Service.

Code: 191 to 198

Display message: COMPUTER ERROR
OPEN DOOR TO RESET

Probable cause: Digital signal processor malfunction.

Corrective action: Open door and close to reset. If error repeats, turn printer power off and back on. If error repeats, call Service.

Code: 199 to 255

Display message: COMPUTER ERROR
POWER OFF AND ON TO RETRY

Probable cause: Nonrecoverable system error.

Corrective action: Turn printer power off, wait 45 seconds and turn power back on. Reload image and try again. If error repeats, call Service.

Technical support and service

In case of difficulty

Most problems (such as empty paper tray, out of ribbon, etc.) will be of the type you can resolve yourself. Some may arise from an incompatibility between the host driver software and the printer machine code. And some may be the result of hardware failures within the printer itself. We suggest the following to help diagnose and solve these problems:

- Check the printer's display panel for error messages. Appropriate action is provided in the "Troubleshooting" section of this manual.
- If this printer has been integrated into a system, review the troubleshooting procedure for that system.

Technical support

If you have tried these suggestions and still need assistance, contact your system supplier for technical support. If it is determined that the problem is within the printer, a service call will be required.

The printer may be under warranty or service agreement to either an authorized service dealer or directly to Kodak. Contact whichever is the appropriate service center for your printer.

The Kodak Customer Service Center can be reached at (800) 3KODAK3—(800) 356-3253—any time of the day. A request for service will be sent to the nearest Kodak service city, and a field engineer will be dispatched. Be prepared to provide the K-Number that appears on the front of the printer.

If the printer is not within the warranty period or covered by a service agreement, customers will be charged on a per-call basis. If the printer is within the warranty period or covered by a service agreement, Kodak will provide service in accordance with the terms of its warranty or service agreement policies.

Glossary

- Color correction** A feature of the XLT 7720 printer which allows you to adjust the tone scale and color of an image to closely match the displayed to the printed image. The printer accomplishes color correction through image sensitometry tables and the speed shift feature.
- Density** A measure of the amount of dye applied to the print material by the printer. Paper prints are all printed at a maximum optical density of 2.5. Transparencies can be printed at one of three (with the black-and-white and color ribbons) or four (with the XLT color ribbon) user-selectable maximum optical density levels that range from 1.5 to 2.7. Your selection will depend on the type of image as well as the viewing device to be used.
- Enhancement** A printer feature that applies sharpening to the printed image.
- IEEE 488** A standard data communications interface to transfer data between a computer and peripheral devices.
- Image sensitometry table** Along with the image calibration table, converts RGB digital pixel values to the desired optical densities produced by the XLT 7720 printer. An image sensitometry table, however, is independent of the print mode (paper print or transparency, ribbon type, density level). Your software driver may allow you to adjust an image sensitometry table to compensate for differences between your monitor display and the XLT 7720 printer, and for the effects of variations in lighting conditions.
- Pixel** The smallest discrete printing element in an image. Image resolution is determined by the number of pixels per unit distance. The pixel resolution of the XLT 7720 printer is 203 pixels per inch.
- Printer driver** A software program that sends documents from a host computer to a particular type of printer. You must have an XLT 7720-specific printer driver that is compatible with your host computer environment.
- SCSI** Small Computer System Interface. A standard parallel data communications interface that transfers data between a computer and peripheral devices.

Sharpening

See **Enhancement**.

Speed shift

A feature that allows you to make uniform color and tone scale corrections to a single image without modifying the current image sensitometry table.

Specifications and general data

Printing specifications

Printing method	Thermal dye transfer
Output options	Reflection prints; transparencies
Output sizes	8.5 x 11 in. (21.59 x 27.94 cm) 11 x 11 in. (27.94 x 27.94 cm) A4 (210 x 297 mm, 8.27 x 11.69 in.)
Maximum image areas	
8.5 x 11-inch & A4 11 x 11-inch	7.56 x 10.08 in. (19.20 x 25.60 cm) 10.08 x 10.08 in. (25.60 x 25.60 cm)
Resolution	
Pixels/inch	203
Pixels/mm	8
Density range	0.07–2.5 (reflection density) 0.05–2.7 (transmission density)
Digital data sizes	
8.5 x 11-inch & A4 11 x 11-inch stock	1536 x 2048 pixel array 2048 x 2048 pixel array
Prints/cartridge*	
Color (XL & XLT)	100
Black-and-white	300
Prints/tray	100 (maximum)

* Reflection prints only. Transparency mode may yield fewer images.

**Physical/
environmental
specifications**

Computer interfaces	IEEE 488 or SCSI (optional)
Dimensions	
Rack-mounted	14 H x 19 W x 22.5 inches D (35.56 H x 48.26 W x 57.15 cm D)
Table-top	15 H x 20 W x 24 inches D (38.10 H x 50.80 W x 60.96 cm D)
Weight	Approximately 130 lbs. (59 kg)
Voltage	100, 120, 220, or 240 V AC, $\pm 10\%$
Current	8 amps maximum at 120 V 5 amps maximum at 240 V
Frequency	50/60 Hz
Ambient temperature	59–86° F (15–30° C)
Ambient humidity	15–76% relative
Standards	
Safety	UL478, CSA C22.2 #220-M 1986, IEC-950 (EN60950)
EMI	VDE 8806 Class B; FCC Rules Part 15, Subpart J, Class A; EEC 499 (1982), European Standard EN 55022

Options and accessories

Kodak XLT 7720 Digital Continuous Tone Printer (configuration options)

Product	Computer Interface	Catalog Number
XLT 7720-CI	IEEE 488	168 7045
XLT 7720-CS	SCSI	160 2085

Kodak Ektatherm products hard copy output options

Product	Material	Size	Catalog Number
XL 100-8P	Paper	8.5 x 11 in.	808 1895
XL 100-11P	Paper	11 x 11 in.	845 3698
XLT 100-A4P	Paper	A4	139 2398
XL 100-8T	Transparency	8.5 x 11 in.	810 6346
XL 100-11T	Transparency	11 x 11 in.	820 4927
XLT 100-A4T	Transparency	A4	179 7711

Kodak Ektatherm ribbon cartridge options

Product	Color	Catalog Number
XL 100-C	Color	804 6146
XLT 100-C	Color	198 7965
XL 300-B	Black and white	808 1614

Accessories

Product	Catalog Number
<i>Kodak XLT Printer IEEE 488 Interface Kit/ XLT 7020</i>	150 3887
<i>Kodak XLT Printer SCSI Interface Kit/ XLT 7022</i>	141 9274
<i>Kodak XL Printer Tray/XL 7040</i>	182 5561
<i>Kodak XL Printer Ribbon Cartridge Protector/XL 7042</i>	142 2708
<i>Kodak XLT Print Catcher/XLT 7044</i>	124 0977
<i>Kodak XLT A4 Printer Tray/XLT 7048</i>	197 7545
<i>Kodak XLT Printer Tabletop Side Panel Kit/ XLT 7050</i>	171 4633
<i>Kodak XLT Printer Rack and Slide Mount Kit/ XLT 7052</i>	129 2655

For information on ordering Kodak equipment, accessories, and supplies, call the KODAK toll-free information number 1-800-44KODAK (1-800-445-6325), Extension 110.

Index

100 V AC line conversion, 13
220 V AC line conversion, 14
240 V AC line conversion, 16

A

Accessories, 52
Annotation, 6
Audio alert, 7

B

Backlit view box, 10

C

Capabilities, 2
Cleaning the print head, 34
Clearing jams in the printer
 Clearing a jam in the finishing station, 33
 Clearing a jam in the print tray, 32
 Clearing material on the print drum under
 error conditions, 33
Color and tone scale adjustment, 3
Color balance, 3
Color correction, 47
Color matrix, 3
Color temperature, 4
Computer interface options, 18
Configuration options, 51
Connecting to the host computer, 18

D

Density levels, 8, 47
Double pass overhead projector, 9

E

Enhancement, 4, 47
Error codes
 134, 138, 38
 139, 144, 145, 39
 146, 147, 148, 153, 40
 160, 161, 162, 163, 41
 164, 165, 166, 167, 42
 168, 169, 180, 43
 181, 182, 183, 190, 44
 191 to 198, 199 to 255, 45

F

- Features, 3
 - Audio alert, 7
 - Color and tone scale adjustment, 3
 - Image composition, 5
 - Image manipulation, 5
 - Image sharpness enhancement, 4
 - Speed shifts, 4
- FEED button, 20

G

- Glossary, 47

H

- Handling your *Kodak Ektatherm* products
 - General, 30
 - Paper and transparency material, 31
 - Paper prints and transparencies, 30
 - Ribbon cartridges, 30
- High efficiency (XLT-100) color ribbon, 10
- Hue, 4

I

- IEEE 488, 18, 21, 47
- Image composition, 5
- Image manipulation
 - Annotation, 6
 - Mirror image, 6
 - Rotation, 6
 - Scaling, 5
 - Time and date, 7
- Image sensitometry table, 3, 47
- Image sharpness enhancement, 4, 47
- Installing the XLT 7720 printer, 11
 - Computer interface options, 18
 - Connecting to the host computer, 18
 - Installing printer driver software, 18
 - Installing the side panel or rack and slide mount kits, 11
 - Line voltage conversion, 12
 - Unlocking the drum assembly, 11
- Interface address, 21

J

- Jams, clearing
 - Clearing a jam in the finishing station, 33
 - Clearing a jam in the print tray, 32
 - Clearing material on the print drum under error conditions, 33

K

- Kodak Customer Service Center, 46
- Kodak TableMaker*, 3

L

- Landscape format, 6
- Language selection switches, 21
- Line voltage conversion
 - 100 V AC line conversion, 13
 - 220 V AC line conversion, 14
 - 240 V AC line conversion, 16

M

- Maintaining the printer, 34
 - Cleaning the print head, 34
 - Good housekeeping, 34
 - Replacing a fuse, 35
 - Replacing the air filter, 36
 - Replacing the battery, 37
- Mirror image, 6
- MODE A/MODE B switch, 20

O

- Options and accessories, 51
 - Accessories, 52
 - Kodak Ektatherm* products hard copy output options, 51
 - Kodak Ektatherm* ribbon cartridge options, 51
 - Kodak XLT 7720 Digital Continuous Tone Printer* (configuration options), 51

P

- Paper prints, 9, 30, 51
- Physical/ environmental specifications, 50
- Pixel, 47
- Portrait format, 6
- Printer driver, 47
- Printing specifications, 49

R

Replacing a fuse, 35
Replacing the air filter, 36
Replacing the battery, 37
Ribbons, 10, 30, 51
Rotation, 6

S

SAMPLE PRINT button, 20
Saturation, 4
Scaling, 5
SCSI, 18, 21, 47
Single pass overhead projector, 9
Specifications and general data, 49
 Physical/ environmental specifications, 50
 Printing specifications, 49
Speed shift, 4, 48
Standard efficiency color ribbon, 10, 51

T

Technical support and service, 46
 In case of difficulty, 46
 Technical support, 46
Thermal dye transfer, 1
Time and date stamp, 7
Tone reproduction, 3
Tone scale, 3
Transparencies, 9, 51
Troubleshooting, 38
 Error codes
 134, 138, 38
 139, 144, 145, 39
 146, 147, 148, 153, 40
 160, 161, 162, 163, 41
 164, 165, 166, 167, 42
 168, 169, 180, 43
 181, 182, 183, 190, 44
 191 to 198, 199 to 255, 45

U

- Using the XLT 7720 printer, 19
 - Clearing jams in the printer, 32
 - Controls and indicators, 19
 - Handling your *Kodak Ektatherm* products, 30
 - Installing the *Kodak Ektatherm* ribbon cartridge, 23
 - Loading *Kodak Ektatherm* print paper or transparency material, 26
 - Making a sample print, 23
 - Powering up, 22

X

- XL 100C color ribbon, 10, 51
- XL 300-B black-and-white ribbon, 10, 51
- XLT 100-C color ribbon, 10, 51

Warranty

Equipment warranty

Kodak warrants throughout the United States that Equipment will conform to Kodak's published specifications and be free from defects in material and workmanship under normal use and service for a period of ninety (90) days from the date of initial installation at an end-user site, not to exceed six (6) months from the date of shipment from Kodak, provided, however, that the Equipment has not been modified in any manner. If the Equipment has been modified, the warranty is voided. If the equipment does not function properly during the warranty period, it will be repaired or replaced at Kodak's option, without charge, during Kodak's normal working hours. Such repair service may be performed by Kodak or an Authorized Service Dealer and will include any adjustments and/or replacement parts required to maintain the Equipment in proper operating order. Repair parts may be new or reconditioned to perform as new. Repair parts supplied under this warranty carry only the unexpired portion of the original warranty.

For sales outside the United States, the warranty will be that stated on or accompanying the package for the *Kodak XLT 7720* Digital Continuous Tone Printer.

Warranty services

The warranty services performed hereunder shall be performed by Kodak or an authorized Service Dealer and only by personnel qualified to perform such services. Such services shall be performed in a professional and workmanlike manner.

Warranty limitations

- i. Warranty service for Equipment is limited to the United States.
- ii. The warranties for this Equipment do not cover: circumstances beyond Kodak's control; service or parts to correct problems resulting from the use of software, supplies, attachments, accessories, or alterations not marketed by Kodak; service required as the result of relocation, unauthorized modifications, or service; misuse; abuse; failure to follow Kodak's operating and maintenance instructions; or failure to maintain site specifications.
- iii. These warranties shall not cover the loss or damage to Product which occurs during shipment.
- iv. The above warranties are in lieu of all other warranties, expressed, implied or statutory, or arising by custom or trade usage, including any warranty or merchantability or fitness for any unique, special, or express purpose and of all other damages whether general or specific, direct or indirect, consequential, incidental, or exemplary.

Service agreements

Service Agreements can be purchased through the system supplier when the equipment is sold. The initial Service Agreement commences on the day after the warranty ends and expires nine months or one year from that date, depending upon whether a nine-month or a one-year agreement is purchased. Agreements are renewable on an annual basis, for a period of five years after initial installation, at the prices, terms, and zones in effect on the renewal date.

Kodak offers both a standard Service Agreement and a Preferred Service Agreement. The Preferred Service Agreement gives extended hours of coverage, along with priority dispatching. For details and further information, or to order a Service Agreement, call the Kodak Service Group at: (800) 3KODAK3; (800) 356-3253.